

PIANO DI RECUPERO DEL CENTRO STORICO
DI "TERRICCIOLA CAPOLUOGO"

VARIANTE RIGUARDANTE LA MODIFICA DELL'AREA A
PARCHEGGIO LUNGO VIA DANTE E VIA DELLA CROCE







Progettista: Dott. Arch. Panicucci Franco
Consulenti Geologi: Dott. Simone Stefani, Dott. Roberta Giorgi

TAV. A/c





STATO DI VARIANTE





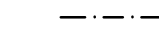
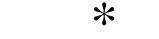

CLASSIFICAZIONE DEGLI EDIFICI IN BASE AL LORO VALORE STORICO-AMBIENTALE E PRESCRIZIONI DI INTERVENTO 1:500

Classificazione degli edifici:









-  Edifici di rilevante valore architettonico-ambientale "RV"
-  Edifici di valore architettonico-ambientale "V"
-  Edifici di minor valore storico-ambientale "MV1"
-  Edifici di minor valore storico-ambientale "MV2"
-  Edifici di valore architettonico-ambientale nullo "N"
-  Edifici ad uso di annesso di valore storico-ambientale minore
-  Edifici o parti di essi architettonicamente e ambientalmente incongrui

Tipi di intervento:

-  Perimetro del centro storico
-  Sistemazione dei fronti tergalii con ampliamento
-  Linea del fronte di ricostruzione
-  Sistemazione dei fronti tergalii
-  Vincolo di facciata
-  Perimetro aree sottoposte a Schema Progettuale Guida

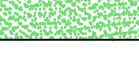
- | | |
|---|---|
|  Manutenzione Straordinaria |  Ristrutturazione Urbanistica |
|  Restauro e Risanamento Conservativo |  Demolizione senza ricostruzione |
|  Ristrutturazione edilizia |  Demolizione o trasformazione |
|  Cantine interrato | |

Riconfigurazione degli spazi pubblici:

- | | |
|--|--|
|  Parcheggi |  Corti e parchi di ville |
|  Strade, piazze e corti |  Verde pubblico |
|  Verde privato |  Attrezzature pubbliche |
|  Percorsi pedonali |  Attrezzature di interesse comune, pubblico o di uso pubblico |

Spazi privati vincolati:

-  Orti, giardini e corti

